

⚠ CAUTION

Battery Charger

- Charge ONLY Ni-MH rechargeable batteries.
- DO NOT connect + and - terminal reversed or let the batteries contact metals such as necklaces or hairpins.
- For indoor use ONLY.
- DO NOT keep plugging for long periods.

BT-2Gm

- Do not reverse the + and - terminals of the battery, and use only the specified type of battery. Otherwise, it will overheat and fail.

For more detailed information about cautions, please refer the "StarBoard BT-2Gm User's guide" in "StarBoard BT-2Gm Setup Software".

⚠ VORSICHT

Laden des Akkus

- Laden Sie NUR Ni-MH-Akkus.
- Die Pole + und - MÜSSEN in der richtigen Reihenfolge angeschlossen werden, und die Akkus dürfen nicht mit metallischen Gegenständen wie Halsketten oder Haarnadeln in Berührung kommen.
- NUR für den Gebrauch in geschlossenen Räumen konzipiert.
- Das Gerät darf NICHT über einen längeren Zeitraum angeschlossen sein.

BT-2Gm

- Die Pole + und - müssen in der richtigen Reihenfolge angeschlossen werden, und es darf nur der angegebene Akku-Typ verwendet werden. Andernfalls kann es zu einer Überhitzung und einem Fehlschlagen des Vorgangs kommen.

Sie finden ausführliche Informationen zu den Warnhinweisen im "StarBoard BT-2Gm Benutzerhandbuch" auf der CD "StarBoard BT-2Gm Setup Software".

⚠ ATTENTION

Chargeur de piles

- Chargez UNIQUEMENT des piles Ni-MH rechargeables.
- ÉVITEZ de connecter les bornes + et - à l'envers ou de laisser les piles en contact avec des objets métalliques tels que colliers ou épingles à cheveux.
- Pour utilisation à l'intérieur UNIQUEMENT.
- ÉVITEZ de laisser branché sur des périodes prolongées.

BT-2Gm

- Évitez d'inverser les bornes + et - de la batterie, et utilisez uniquement le type de pile spécifié. Autrement, la pile surchauffera et sera endommagée.

Pour de plus amples informations sur les mises en garde, reportez-vous au « Guide de l'utilisateur du StarBoard BT-2Gm » dans le « StarBoard BT-2Gm Setup Software ».

⚠ ATTENZIONE

Caricabatterie

- Ricaricare SOLO batterie ricaricabili Ni-MH.
- NON collegare le batterie invertendo la polarità + e - dei contatti ed evitare che le batterie entrino in contatto con metalli, ad es. collane o spille.
- ESCLUSIVAMENTE per uso in interni.
- NON mantenere collegato per lunghi periodi.

BT-2Gm

- Non invertire la polarità + e - dei contatti della batteria, e utilizzare solo il tipo specificato di batteria. In caso contrario, la batteria si surriscalderebbe e si guasterebbe.

Per informazioni più dettagliate relative alle avvertenze, consultare la "Guida per l'utente di StarBoard BT-2Gm" in "StarBoard BT-2Gm Setup Software".

⚠ ATENCIÓN

Cargador de pilas

- Utilice SÓLO pilas recargables de Ni-MH.
- NO coloque los terminales + y - al revés y evite que las pilas entren en contacto con objetos metálicos como, por ejemplo, collares u horquillas.
- SÓLO para uso en interiores.
- NO dejar enchufado durante largos periodos de tiempo.

BT-2Gm

- No invierta los terminales + y - de la pila y use únicamente el tipo de pila especificado. De lo contrario, la pila se sobrecalentará y funcionará incorrectamente.

Para obtener información más detallada sobre las precauciones, consulte "Manual del usuario de StarBoard BT-2Gm" en "StarBoard BT-2Gm Setup Software".

Setup Hardware

1. Insert batteries to tablet and pen.

Please full-charge the batteries, before the first usage.

-Tablet-

AA batteries*2

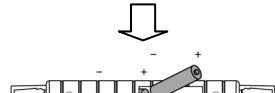
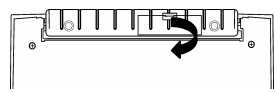

-Pen-

AAA batteries*1

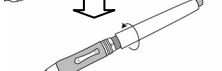
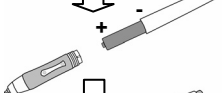
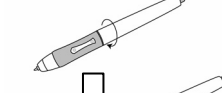

2. Power on tablet and pen.

-Tablet-

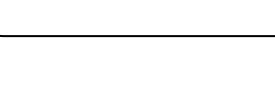
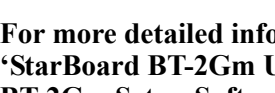
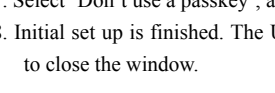
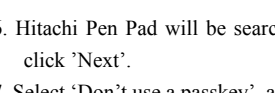
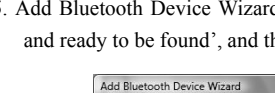
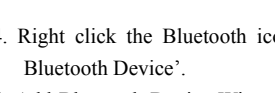
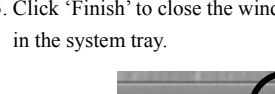
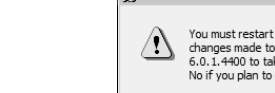
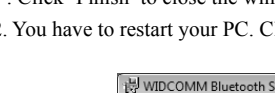
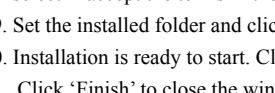
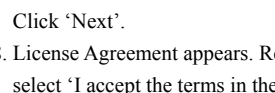
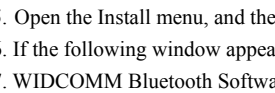
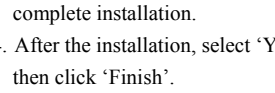
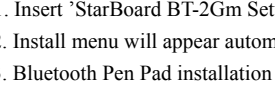
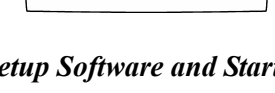
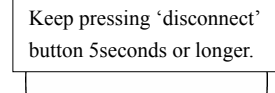
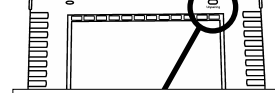
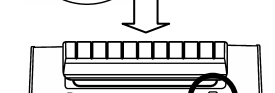
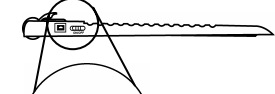

-Pen-

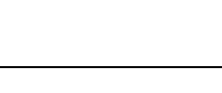
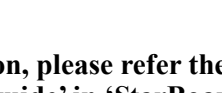
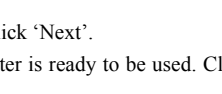
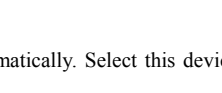
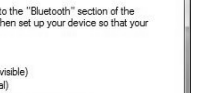
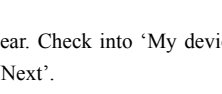
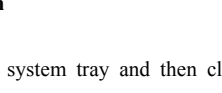
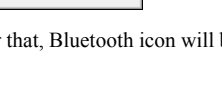
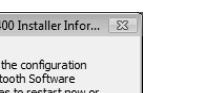
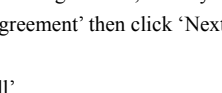
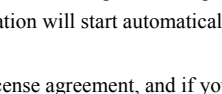
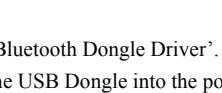
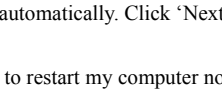
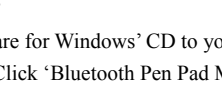
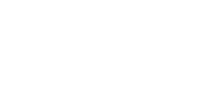
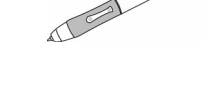
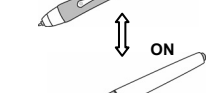
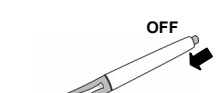

Setup Software and Start to use

1. Insert 'StarBoard BT-2Gm Setup Software for Windows' CD to your PC.
2. Install menu will appear automatically. Click 'Bluetooth Pen Pad Manager'.
3. Bluetooth Pen Pad installation will start automatically. Click 'Next' to complete installation.
4. After the installation, select 'Yes, I want to restart my computer now' and then click 'Finish'.
5. Open the Install menu, and then, click 'Bluetooth Dongle Driver'.
6. If the following window appears, plug the USB Dongle into the port.
7. WIDCOMM Bluetooth Software Installation will start automatically. Click 'Next'.
8. License Agreement appears. Read the license agreement, and if you accept, select 'I accept the terms in the license agreement' then click 'Next'.
9. Set the installed folder and click 'Next'.
10. Installation is ready to start. Click 'Install'.
11. Click 'Finish' to close the window.
12. You have to restart your PC. Click 'Yes'.

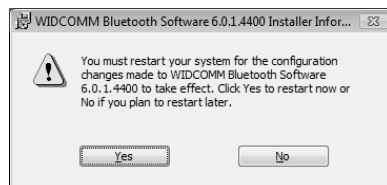

13. Click 'Finish' to close the window. After that, Bluetooth icon will be showed in the system tray.



Bluetooth Icon

14. Right click the Bluetooth icon in the system tray and then click 'Add a Bluetooth Device'.
15. Add Bluetooth Device Wizard will appear. Check into 'My device is set up and ready to be found', and then click 'Next'.



16. Hitachi Pen Pad will be searched automatically. Select this device and then click 'Next'.
17. Select 'Don't use a passkey', and then click 'Next'.
18. Initial set up is finished. The USB adapter is ready to be used. Click 'Finish' to close the window.

For more detailed information, please refer the 'StarBoard BT-2Gm User's guide' in 'StarBoard BT-2Gm Setup Software' CD.

English

Einrichtung der Hardware

1. Setzen Sie die Batterien für Tablett und Stift ein.

Vor der ersten Verwendung müssen die Batterien vollständig geladen werden.

-Tablett-

AA-Batterien*2

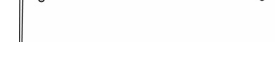
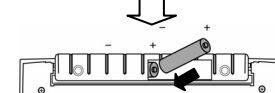
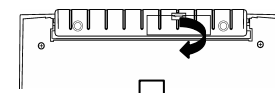

-Stift-

AAA

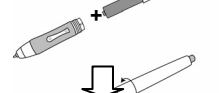
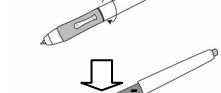

2. Schalten Sie Tablett und Stift ein.

-Tablett-

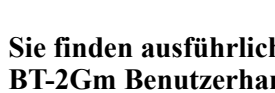
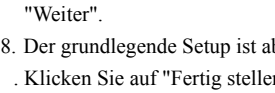
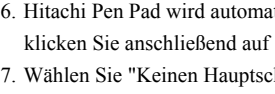
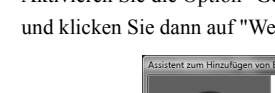
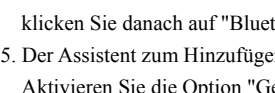
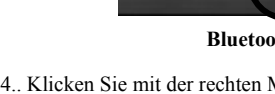
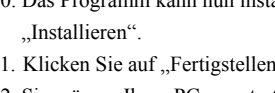
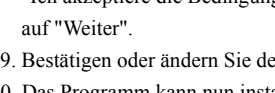
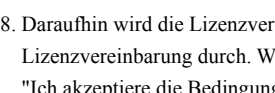
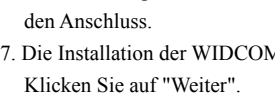
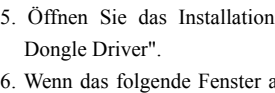
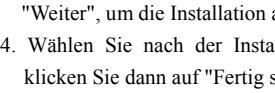
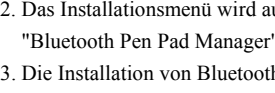
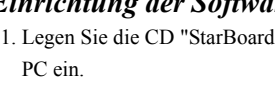
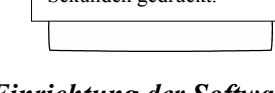
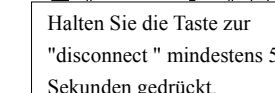
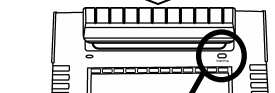
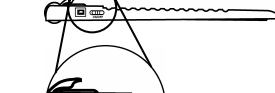

-Stift-

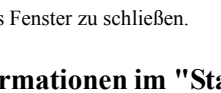
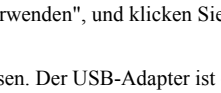
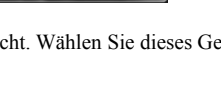
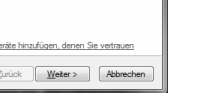
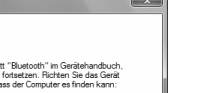
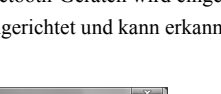
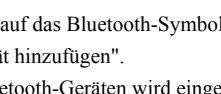
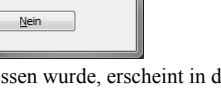
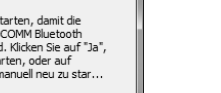
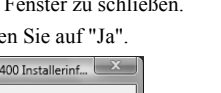
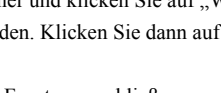
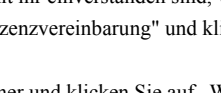
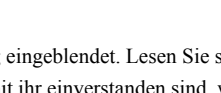
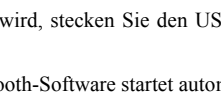
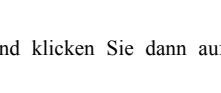
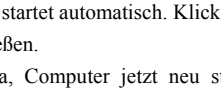
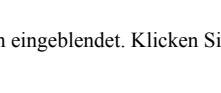
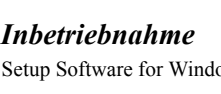
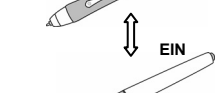
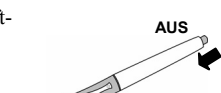

Einrichtung der Software und Inbetriebnahme

1. Legen Sie die CD "StarBoard BT-2Gm Setup Software for Windows" in Ihren PC ein.
2. Das Installationsmenü wird automatisch eingeblendet. Klicken Sie auf "Bluetooth Pen Pad Manager".
3. Die Installation von Bluetooth Pen Pad startet automatisch. Klicken Sie auf "Weiter", um die Installation abzuschließen.
4. Wählen Sie nach der Installation "Ja, Computer jetzt neu starten.", und klicken Sie dann auf "Fertig stellen".
5. Öffnen Sie das Installationsmenü, und klicken Sie dann auf "Bluetooth Dongle Driver".
6. Wenn das folgende Fenster angezeigt wird, stecken Sie den USB-Dongle in den Anschluss.
7. Die Installation der WIDCOMM Bluetooth-Software startet automatisch. Klicken Sie auf "Weiter".
8. Daraufhin wird die Lizenzvereinbarung eingeblendet. Lesen Sie sich die Lizenzvereinbarung durch. Wenn Sie mit ihr einverstanden sind, wählen Sie "Ich akzeptiere die Bedingungen der Lizenzvereinbarung" und klicken dann auf "Weiter".
9. Bestätigen oder ändern Sie den Zielordner und klicken Sie auf „Weiter“.
10. Das Programm kann nun installiert werden. Klicken Sie dann auf „Installieren“.
11. Klicken Sie auf „Fertigstellen“, um das Fenster zu schließen.
12. Sie müssen Ihren PC neu starten. Klicken Sie auf "Ja".



13. Wenn die Installation normal abgeschlossen wurde, erscheint in der Taskleiste das Bluetooth-Symbol.



Bluetooth-Symbol

14. Klicken Sie mit der rechten Maustaste auf das Bluetooth-Symbol, und klicken Sie danach auf "Bluetooth-Gerät hinzufügen".
15. Der Assistent zum Hinzufügen von Bluetooth-Geräten wird eingeblendet. Aktivieren Sie die Option "Gerät ist eingerichtet und kann erkannt werden", und klicken Sie dann auf "Weiter".



16. Hitachi Pen Pad wird automatisch gesucht. Wählen Sie dieses Gerät, und klicken Sie anschließend auf "Weiter".
17. Wählen Sie "Keinen Hauptschlüssel verwenden", und klicken Sie danach auf "Weiter".
18. Der grundlegende Setup ist abgeschlossen. Der USB-Adapter ist einsatzbereit. Klicken Sie auf "Fertig stellen", um das Fenster zu schließen.

Sie finden ausführliche Informationen im "StarBoard BT-2Gm Benutzerhandbuch" auf der CD "StarBoard BT-2Gm Setup Software".

Deutsch

Installer le matériel**Français**

1. Insérez les piles dans la tablette et le stylet.
Chargez complètement les piles avant la première utilisation.

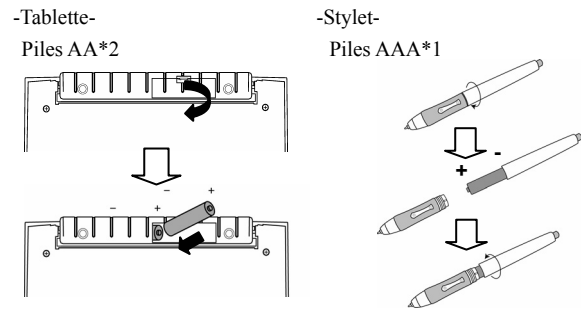

2. Allumez la tablette et le stylet.

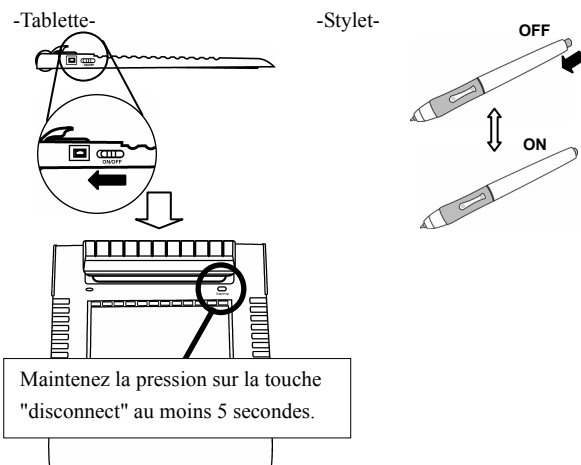
**Installer le logiciel et commencer l'utilisation**

1. Insérez le CD « StarBoard BT-2Gm Setup Software for Windows » dans l'ordinateur. »
2. Le menu d'installation apparaîtra automatiquement. Cliquez sur « Bluetooth Pen Pad Manager ».
3. L'installation de « Bluetooth Pen Pad » est automatiquement lancée. Cliquez sur « Suivant » pour terminer l'installation.
4. Après l'installation, sélectionnez « Oui, je veux redémarrer mon ordinateur maintenant. », puis cliquez sur « Terminer ».
5. Ouvrez le menu d'installation, puis cliquez sur « Bluetooth Dongle Driver ».
6. Si la fenêtre suivante apparaît, branchez le dongle USB dans le port.
7. L'installation du logiciel WIDCOMM Bluetooth est automatiquement lancée. Cliquez sur « Suivant ».
8. Le contrat de licence apparaît. Lisez le contrat de licence et si vous en acceptez les termes, sélectionnez « J'accepte les termes de ce contrat de licence », puis cliquez sur « Suivant ».
9. Spécifiez le dossier d'installation et cliquez sur « Suivant ».
10. L'installation est prête à commencer. Cliquez sur « Installer ».
11. Cliquez sur « Terminer » pour fermer la fenêtre.
12. Vous devez redémarrer l'ordinateur. Cliquez sur « Oui ».



13. Si l'installation s'achève normalement, l'icône Bluetooth apparaîtra dans la barre d'état système.

**Icône Bluetooth**

14. Cliquez sur l'icône Bluetooth d'un clic droit, puis cliquez sur « Ajouter un périphérique Bluetooth ».
15. L'assistant d'ajout d'un périphérique Bluetooth (Add Bluetooth Device Wizard) apparaît. Cochez « Mon périphérique est configuré et prêt à être détecté. », puis cliquez sur « Suivant ».

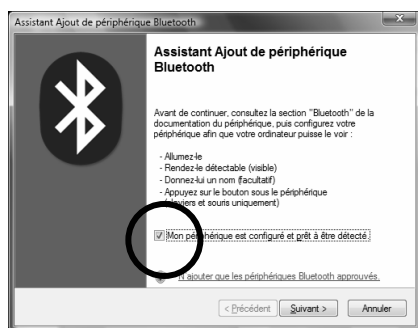

16. L'assistant recherchera automatiquement Hitachi Pen Pad. Sélectionnez ce périphérique, puis cliquez sur « Suivant ».
17. Sélectionnez « Ne pas utiliser de clé de sécurité », puis cliquez sur « Suivant ».
18. La configuration initiale est terminée. L'adaptateur USB est prêt pour l'utilisation. Cliquez sur « Terminer » pour fermer la fenêtre.

Pour de plus amples informations, reportez-vous au « Guide de l'utilisateur du StarBoard BT-2Gme » dans le CD « StarBoard BT-2Gm Setup Software ».

Installazione hardware**Italiano**

1. Inserire le batterie nella tavoletta e nella penna.
Caricare completamente le batterie prima di utilizzarle per la prima volta.

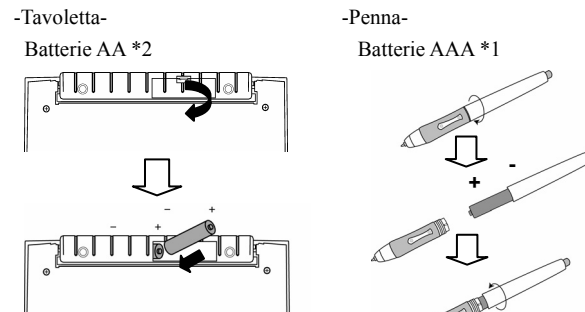

2. Accendere la tavoletta e la penna.

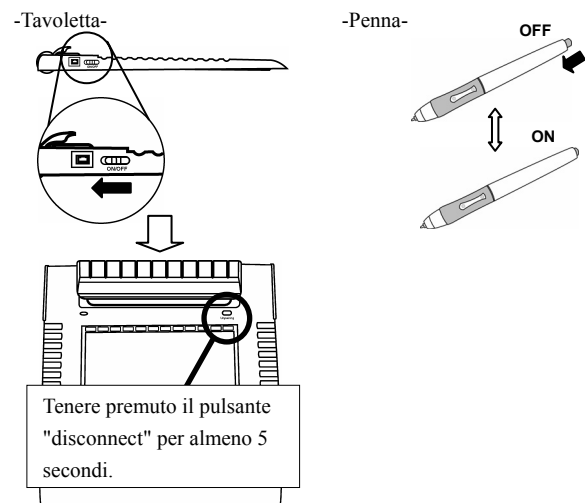
**Configurare il software e iniziare a utilizzare il prodotto**

1. Inserire il CD "StarBoard BT-2Gm Setup Software" nel PC.
2. Il menu di installazione viene visualizzato automaticamente. Fare clic su «Bluetooth Pen Pad Manager».
3. L'installazione di Bluetooth Pen Pad si avvia automaticamente. Fare clic su «Avanti» per completare l'installazione.
4. Dopo l'installazione, selezionare «Riavvia il computer adesso.», quindi fare clic su «Fine».
5. Aprire il menu di installazione, quindi fare clic su «Bluetooth Dongle Driver».
6. Se viene visualizzata la finestra seguente, collegare il dongle USB alla porta.
7. L'installazione di WIDCOMM Bluetooth Software si avvia automaticamente. Fare clic su «Avanti».
8. Viene visualizzato il contratto di licenza. Leggere il contratto di licenza; se lo si accetta, selezionare «Accetto i termini del contratto di licenza», quindi fare clic su «Avanti».
9. Impostare la cartella installata e fare clic su "Avanti".
10. L'installazione è pronta per essere avviata. Fare clic su "Installa".
11. Fare clic su "Fine" per chiudere la finestra.
12. È necessario riavviare il PC. Fare clic su «Sì».

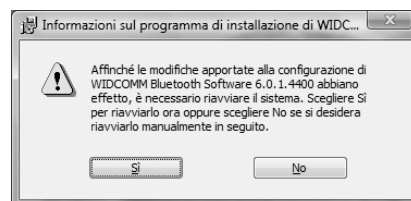

13. Se l'installazione è stata completata normalmente, l'icona Bluetooth apparirà nella barra delle applicazioni.

**Icona Bluetooth**

14. Fare clic con il pulsante destro del mouse sull'icona Bluetooth, quindi fare clic su «Aggiungi dispositivo Bluetooth».
15. Viene visualizzata la procedura guidata Aggiungi dispositivo Bluetooth. Selezionare «Il dispositivo è configurato ed è pronto per il rilevamento», quindi fare clic su «Avanti».



16. L'Hitachi Pen Pad viene cercato automaticamente. Selezionare questo dispositivo, quindi fare clic su «Avanti».
17. Selezionare «Non utilizzare nessuna passkey», quindi fare clic su «Avanti».
18. La configurazione iniziale è terminata. L'adattatore USB è pronto all'uso. Fare clic su «Fine» per chiudere la finestra.

Per informazioni più dettagliate, consultare la "Guida per l'utente di StarBoard BT-2Gm" nel CD "StarBoard BT-2Gm Setup Software".

Instalación del hardware**Español**

1. Inserte las pilas en la pizarra y el lápiz.
Las pilas deben estar totalmente cargadas antes de usarlas por primera vez.

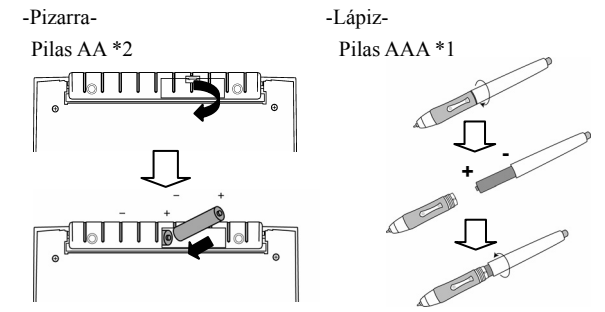

2. Encienda la pizarra y el lápiz.

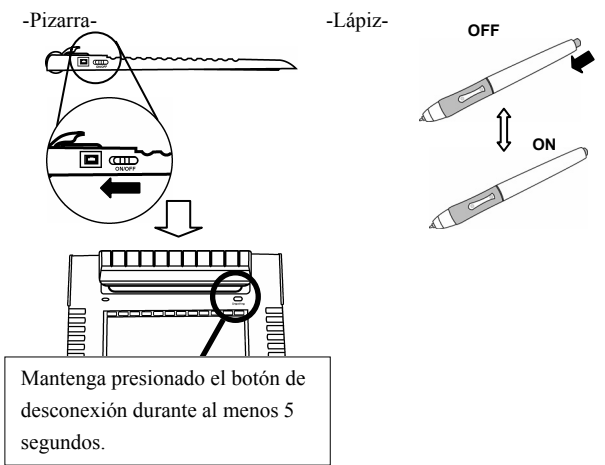
**Instalación y uso del software**

1. Inserte el CD 'StarBoard BT-2Gm Setup Software for Windows' en su PC.
2. El menú de instalación aparecerá automáticamente. Haga clic en «Bluetooth Pen Pad Manager».
3. La instalación de Bluetooth Pen Pad se iniciará automáticamente. Haga clic en «Siguiente» para finalizar la instalación.
4. Después de la instalación, seleccione «Sí, deseo reiniciar el equipo ahora.» y haga clic en «Finalizar».
5. Abra el menú de instalación y haga clic en «Bluetooth Dongle Driver».
6. Si aparece la siguiente ventana, enchufe la mochila USB en el puerto.
7. La instalación del software de Bluetooth WIDCOMM se iniciará automáticamente. Haga clic en «Siguiente».
8. Aparecerá el Contrato de Licencia. Lea el contrato de licencia, y si está de acuerdo, seleccione «Acepto los términos del contrato de licencia» y a continuación haga clic en «Siguiente».
9. Establezca la carpeta de instalación y haga clic en "Siguiente".
10. Ya puede iniciarse la instalación. Haga clic en "Instalar".
11. Haga clic en "Finalizar" para cerrar la ventana.
12. Es necesario reiniciar el PC. Haga clic en «Sí».



13. Si la instalación se ha completado correctamente, aparecerá el icono Bluetooth en la bandeja del sistema.

**Icono Bluetooth**

14. Haga clic derecho en el icono de Bluetooth y a continuación haga clic en «Agregar un dispositivo Bluetooth».
15. Aparecerá el Asistente para Agregar un dispositivo Bluetooth. Marque «Mi dispositivo está configurado y listo para ser detectado», y haga clic en «Siguiente».

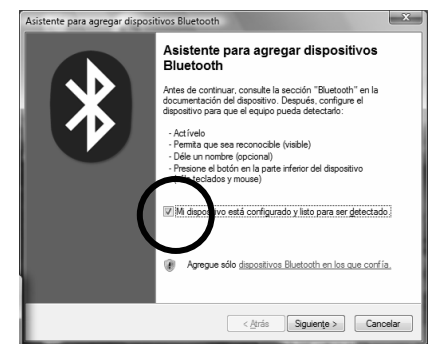

16. La unidad Hitachi Pen Pad se buscará automáticamente. Seleccione este dispositivo y haga clic en «Siguiente».
17. Seleccione «No usar ninguna clave de paso», y haga clic en «Siguiente».
18. La configuración inicial ha finalizado. Ya puede usarse el adaptador USB. Haga clic en «Finalizar» para cerrar la ventana.

Para obtener más información, consulte "Manual del usuario de StarBoard BT-2Gm" en el CD "StarBoard BT-2Gm Setup Software".